



60 Ah *Advanced Lithium* APU/Engine Start Battery

LITHIUM POLYMER BATTERIES

The 60 Ah APU/Engine Start Battery from Panacis represents the next generation in advanced batteries for aerospace applications. What sets the 60 Ah APU/Engine Start Battery apart from competitors is its use of advanced lithium battery technology. Panacis' advanced lithium batteries feature Dow Kokam large format lithium polymer cells, which offer significant advantages over existing battery technologies on the market, such as Nickel Cadmium (NiCad) and Sealed Lead Acid (SLA). Specifically, this battery technology offers a 40 lbs weight savings and 20% energy increase, which results in lower fuel costs to operate the aircraft. Enhanced battery life is also achieved, which ensures that the battery can remain operational longer before it has to be replaced.

Safety and reliability is designed into every Panacis-built advanced lithium battery. Thanks to advanced engineering capabilities, Panacis takes the lithium technology to the next level with integrated electronics and software to maximize battery performance. The battery is capable of backward integration, which makes installation straightforward and inexpensive. This unique capability, coincided with long term cost savings of operation, makes the Panacis 60 Ah APU/Engine Start Battery a smart investment for any organization looking to increase the efficiency and effectiveness of their aircraft.

FEATURES	KEY BENEFITS
> Designed to operate off the 28 VDC bus	> Direct replacement of NiCad or SLA batteries
> High-rate cell balancing	> Capable of balancing during high loads
> High efficiency built-in precision charger (95%)	> Increased battery life
> Electronic current control	> Never worry about damaged starters/ generators or over-torquing
> Electro-Batt 60 @ 53 lbs replaces a 48 Ah NiCad or Lead Acid @ 95+ lbs	> Increased weight savings result in increased fuel savings for the aircraft
> Generation III lithium cell chemistry	> Results in low volatility
> External State of Charge (SOC) indication	> Never have to guess the SOC
> -40° to 80°C discharge capability	> Adaptable to different environment temperatures
> 20-32VDC regulated or unregulated input	> Turnkey-ready for different aircraft systems
> Built-in auto cell balancing	> Increased battery efficiency and lifespan
> ARINC 429 data bus capable	> Interface capability with new generation aircraft requiring ARINC 429 as well as older aircraft that do not utilize ARINC 429 data buses for the battery



APPLICATIONS

- Airborne
- Engine starts requiring up to 1,200 amps initial current
- Direct Replacement for Lead Acid and NiCad batteries of 25 to 40 amps often in a smaller footprint
- Can also be used as a backup battery
- Military Ground Vehicles

Benefit from the drop-in replacement of existing battery systems

TECHNICAL SPECIFICATIONS

Special Mounting

> Per customer requirements

DC Connector (J1)

> MS18093/MS3509

Nominal Voltage

> 25.9 VDC avg.

Qual

- > DO-160E
- > DO-311
- > DO-178B

Nominal Capacity

> 60 Ah (initial)

Electronics

- > High efficiency charger
- > 20-32 VDC Input
- > Automatic cell balancing
- > State of Charge Indication
- > 1600 amp rated internal solid state contactor

Dimensions

- > Length 13.84 in / 351.54 mm
- > Width 9.72 in / 246.89 mm
- > Height 7.63 in / 193.80 mm
- > Weight 53 lbs / 24.1 kg

Safety

Designed into all our lithium batteries

- Less than one chance in a billion of catastrophic failure
- Extensive and redundant electronic controls and continuous monitoring of battery
- Over-charge cutoff protection
- Over-discharge cutoff protection
- Thermal cutoff protection for cells and electronics
- Patented cell monitoring
- Unique packaging concept for added protection

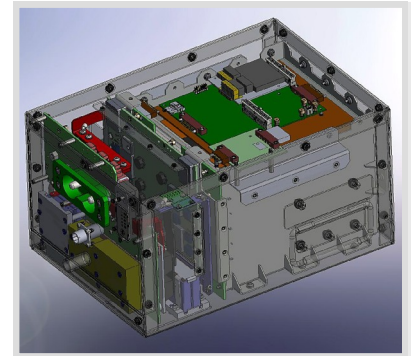

> Cut away drawing of the 60 Ah battery for the AH-1 Super Cobra. The high power electronics and magnetics are a common platform for all Panacis lithium batteries. The heavy use of electronics and magnetics represent a breakthrough in engineering development.

Panacis develops custom battery systems
Contact us with your requirements

Typical Dimensions
Custom chassis can be accommodated

